



Construction

Vertical column sump pumps, with motor in dry installation and with pump body submerged in the liquid handled (without suction line or foot valve).

Impeller - VAL: free-flow impeller (vortex or recessed impeller).
- SC: open impeller.

Connection - VAL 30, SC 30, SC 50: threaded port ISO 228 (BS 2779).
- VAL 65: flange with plain face oval threaded counter-flange UNI 2245, PN 2,5.

Applications

For draining a basin or a sump with domestic or industrial sewage. For slightly dirty waste water, for liquids which are non-aggressive for the pump materials.

Operating conditions

Liquid temperature up to 40 °C.
Ambient temperature up to 40 °C.
Continuous duty.
Maximum size of solids: VAL 30 = 25 mm; VAL 65 = 50 mm;
SC 30 = 3 mm; SC 50 = 6 mm.

Motor

2-pole induction motor, 50 Hz ($n \approx 2900$ rpm).
VAL -SC: three-phase 230/400 V $\pm 10\%$.
VALM-SCM: single-phase 230 V $\pm 10\%$, with thermal protector.
Insulation class F.
Protection IP 54.
Classification scheme IE2 for three-phase motors from 0,75 kW.
Constructed in accordance with: EN 60034-1; EN 60034-30.
EN 60335-1, EN 60335-2-41.

Materials

Components	VAL	SC
Pump casing Lower bearing housing*	Cast iron GJL 200 EN 1561	Cast iron GJL 200 EN 1561
Impeller	Brass P-Cu Zn 40 Pb 2 UNI 5705 for VAL 30	Brass P-Cu Zn 40 Pb 2 UNI 5705
	Cast iron GJL 200 EN 1561 for VAL 65	
Shaft	Steel C 40 UNI 7231	
Bearing bush	Tecno polymer	
Shaft sleeve	Chromate bronze for VAL 65	-

* Not existing for VAL 30.

Special features on request

- Other voltages.
- Frequency 60 Hz (as per 60 Hz data sheet).
- Protection IP 55.
- Bronze bearing bush (for liquid up to 100 °C).
- Higher ambient temperatures.

Characteristic Curves $n \approx 2900$ rpm

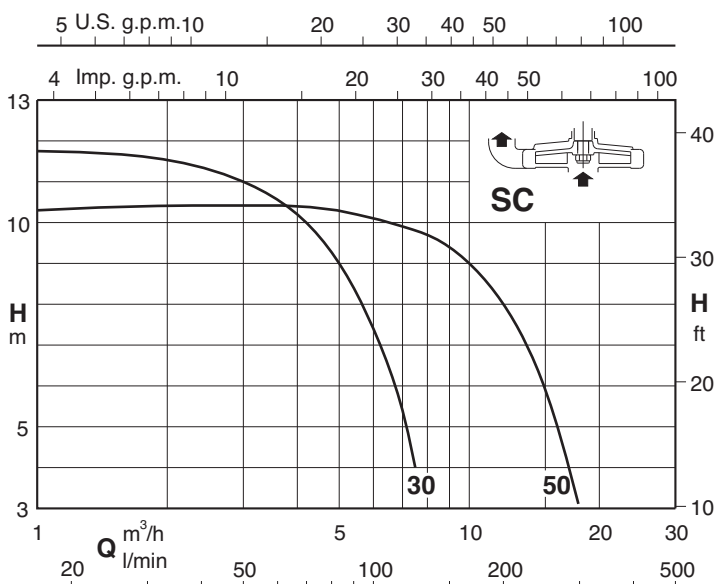
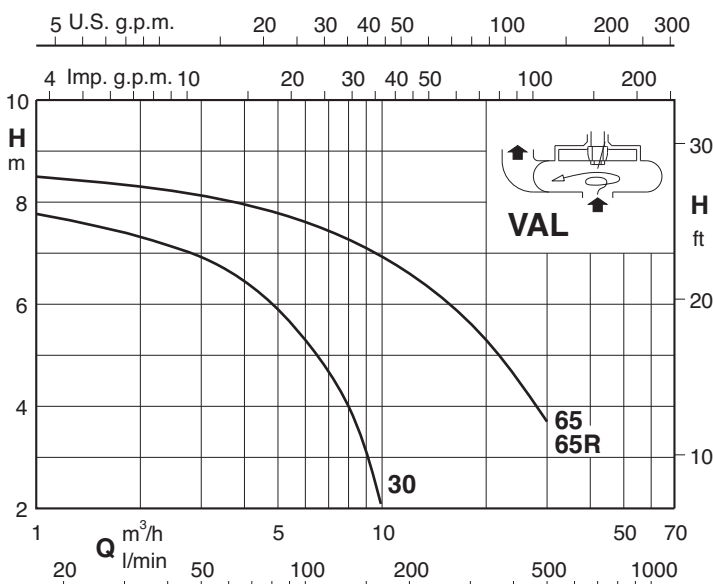

Performance $n \approx 2900$ rpm

	3 ~ 230V 400V		1 ~ 230V		P ₁		P ₂		Q m ³ /h l/min	H m																	
	A	A	A	kW	kW	HP	3	3,5		4	4,5	5	5,5	6	6,5	7	7,5	8	9	10	12	14	16	18	20	25	30
VAL 30/A	2,3	1,3	VALM 30/A	3,6	0,63	0,45	0,6	50	58,3	66,6	75	83,3	91,6	100	108	116	125	133	150	166	200	233	266	300	333	416	500
VAL 65E	7,5	4,3				1,5	2		6,7	6,5	6,2	5,9	5,6	5,3	5	4,7	4,3	4	3	2							
VAL 65-R/A	9,15	5,3				2,2	3												7,1	6,9	6,6	6,3	6	5,6	5,3	4,5	3,7
SC 30/A	2,3	1,3	SCM 30/A	2,8	0,47	0,37	0,5	11	10,6	10,2	9,6	9	8,3	7,4	6,5	5,4	4										
SC 50/A	2,3	1,3	SCM 50/A	3,6	0,69	0,45	0,6					10,3	10,2	10,1	10	9,9	9,8	9,7	9,4	9	8	6,7	5	3			

P1 Max. power input.

P2 Rated motor power output.

H Total head in m.

Tolerances according to UNI EN ISO 9906:2012

Dimensions and weights

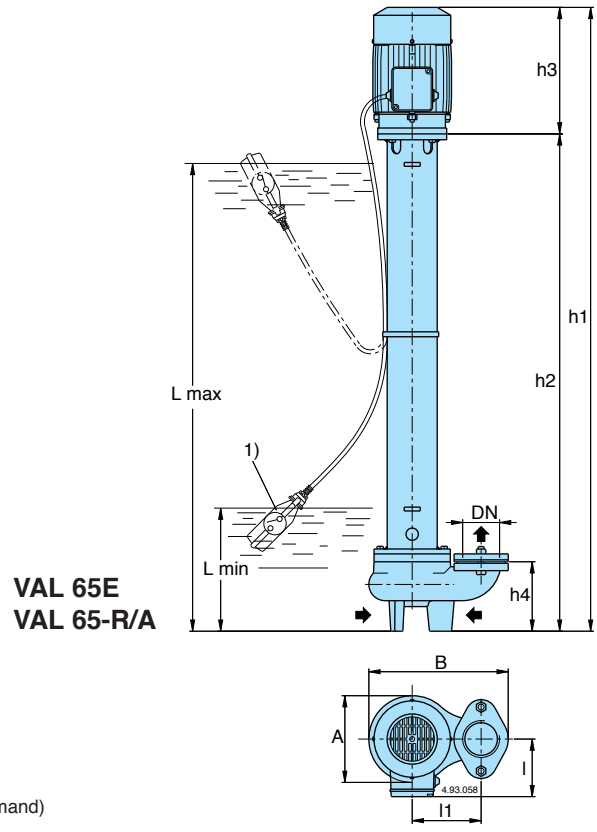
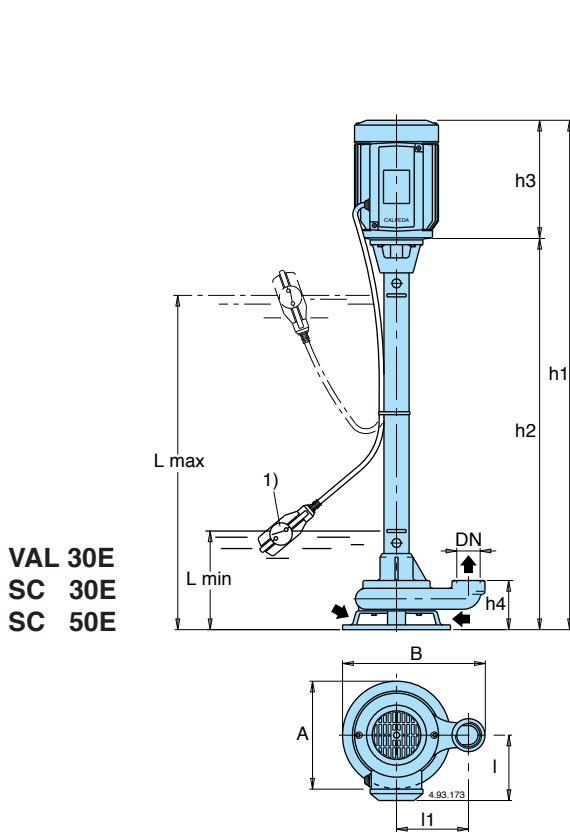

1) Float switch (on demand)

TYPE	DN ISO 228	mm										kg
		h1	h2	h3	h4	I	l1	L min	L max	A	B	
VAL 30/750/A	G 1 1/4	1025	825	200	82	111	120	150	750	180	235	17,8
VAL 30/1000/A		1275	1075						1000			19,5
VAL 65/1000E		1245	1010						950			40
VAL 65/1500E	G 2 1/2	1745	1510	235	140	135	140	250	1450	175	283	48
VAL 65/2000E		2245	2010						1950			56
VAL 65/2500E		2745	2510						2450			64
VAL 65/1000-R/A	G 2 1/2	1285	1010	275	140	135	140	250	950	175	283	43
VAL 65/1500-R/A		1785	1510						1450			51
VAL 65/2000-R/A		2285	2010						1950			59
VAL 65/2500-R/A		2785	2510						2450			67
SC 30/500/A	G 1 1/4	765	565	200	105	111	100	200	455	132	192	17,4
SC 30/750/A		1015	815						705			19,6
SC 30/1000/A		1265	1065						955			21,8
SC 30/1250/A		1515	1315						1205			24
SC 50/500/A	G 2	780	580	200	120	111	120	215	470	173	243	18,5
SC 50/750/A		1030	830						720			20,7
SC 50/1000/A		1280	1080						970			22,9
SC 50/1250/A		1530	1330						1220			25,1

Characteristic curves $n \approx 2900$ rpm

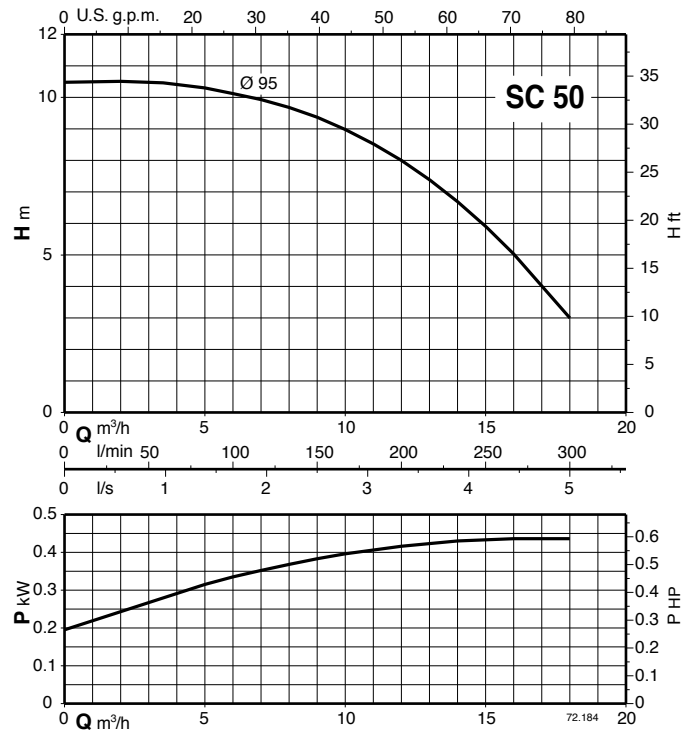
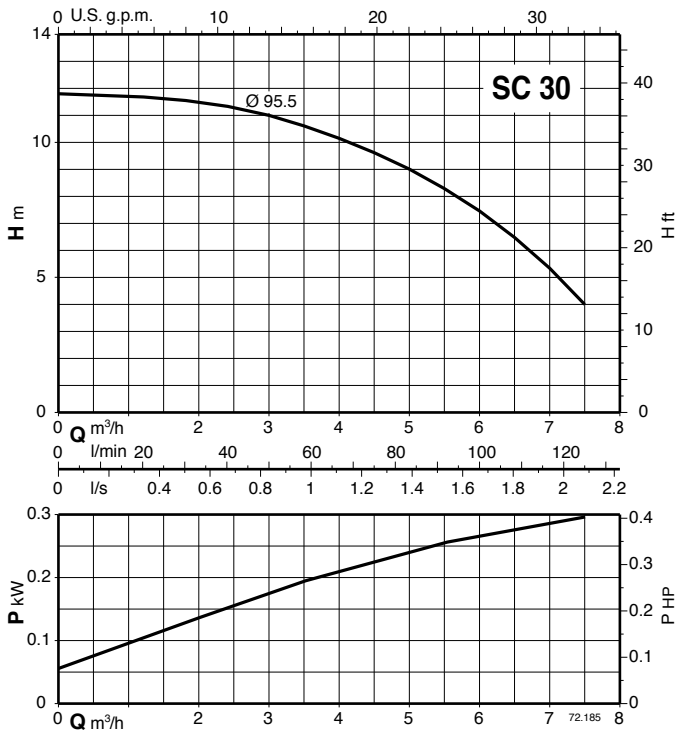
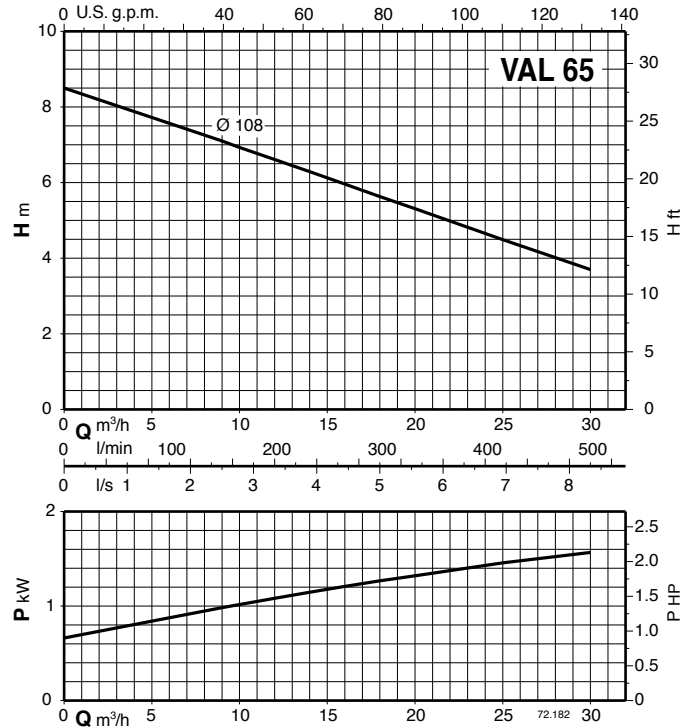
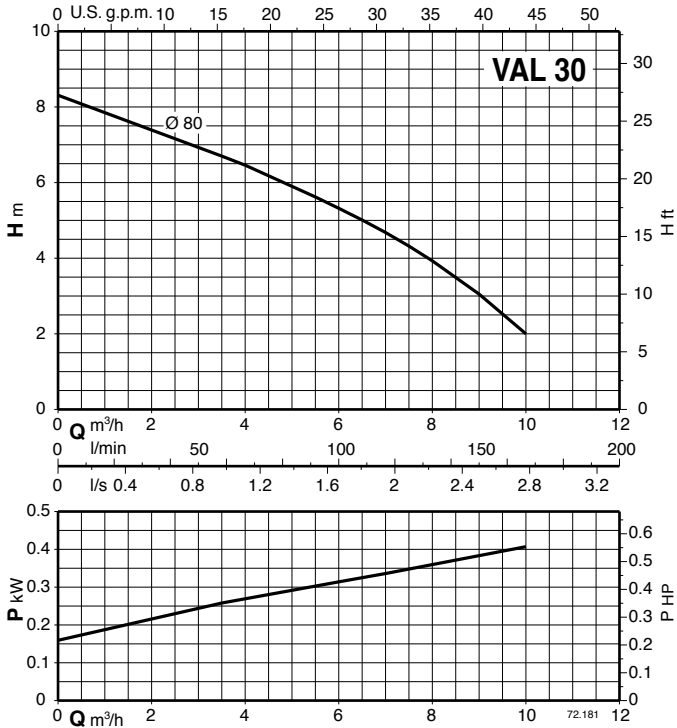

Features

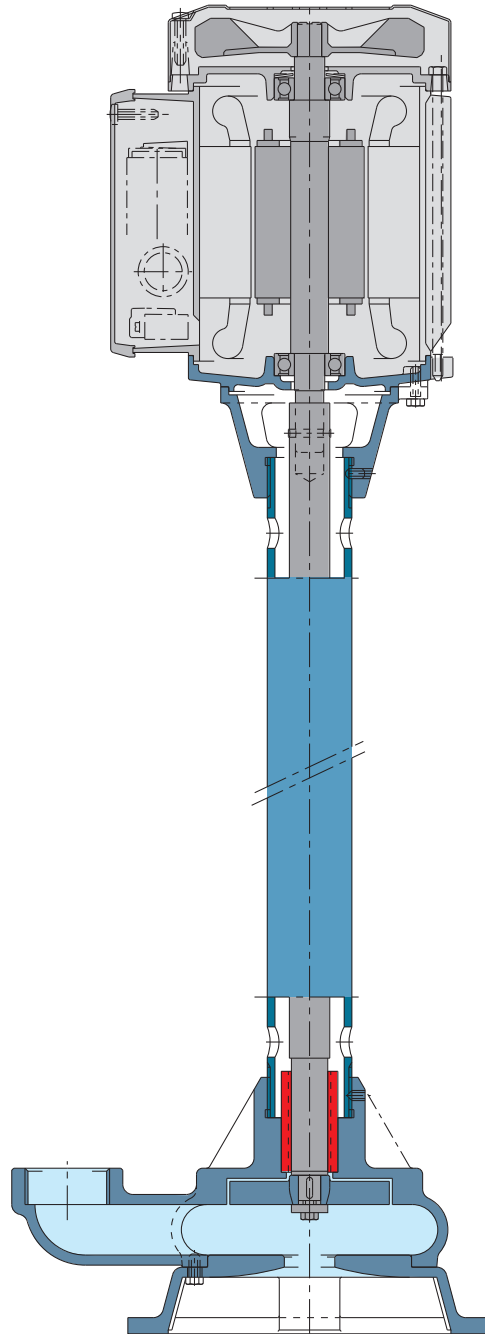

Range

The high number of pumps in the range can meet the widest range of services required by the user.

Construction with no mechanical seal

The absence of a mechanical seal minimizes the need for maintenance of the pumps.

Float switch

The pumps can be fitted with a float switch, eliminating the need for level control systems.